

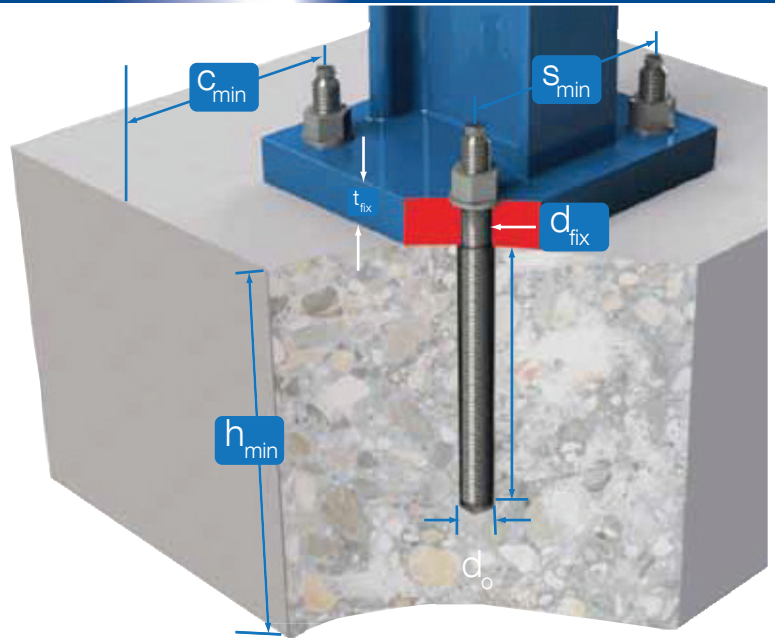

SUPERCAP

Glass Capsules

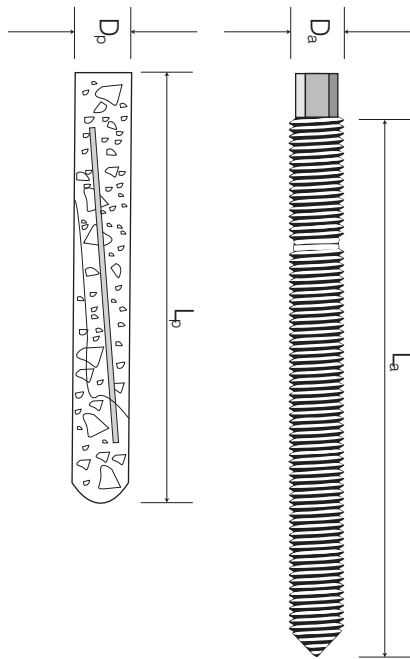

CE 1109	
Chemfix Products Ltd	
09/0192	
	
CPD-0046	
Chemfix Products Ltd 09/0192	
ETAG 001-5 Option 8	
M8 - M24	
European Technical Approval	
Option 8 for uncracked concrete	



Features

- ETA Approved Glass capsule for concrete
- Fixing Anchor holes are drilled with either Rotary Drill Hammers or Diamond Drill Rigs.
- For Horizontal, Vertical or Overhead applications
- For use with M8 - M30 Anchor Studs Carbon Steel 5.8, 8.8 + Stainless Steel Grades



Parameters

- Range of Loading 3.0kN to 60.0kN
- Range of Concrete Quality C12/15 to C50/60 +
- Used in Cracked or Uncracked Concrete under 09/0912
- For installation in Wet or Dry holes

Sizes

- M8 - M10 - M12 - M16 - M20 - M24 - M30
- V_p = Volume per Capsule
- V_s = Required Volume per cm Depth
- 6-10 pcs per packing case

SUPERCAP

Glass Capsules

Capsule Specifications

D_a	L_a (mm)	Capsule Type	D_p (mm)	L_p (mm)	V_p cc	V_s cc/cm
M8	110	P-E	9	80	4.0	0.44
M10	130	P-E	11	80	5.5	0.59
M12	160	P-E	13	95	9.0	0.75
M16	190	P-E	17	95	15.8	0.94
M20	260	P-E	22	175	53.0	2.64
M24	300	P-E	24	210	76.0	2.87
M30	360	P-E	33	265	191.0	4.37

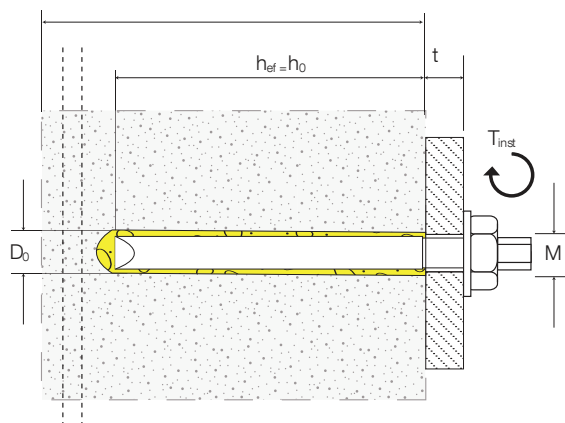

Setting Dimensions

D_a	d_0 (mm)	h_0 (mm)	d_r (mm)	h_{min} (mm)	t_{fix} (mm)	T_{inst} Nm
M8	10	80	9	110	20	10
M10	12	90	12	120	30	20
M12	14	110	14	140	37	40
M16	18	125	18	160	49	80
M20	25	170	22	220	75	120
M24	28	210	26	260	67	180
M30	35	280	33	350	52	300

SUPERCAP

Glass Capsules

Typical Performance Data - Recommended Loads - 5.8 Grade Steel

Type	Concrete Class		Unit	M8	M10	M12	M16	M20	M24	M30*
Characteristic Resistance	C20/25	N _{RR}	kN	18.0	29.0	40.0	50.0	75.0	89.9	139.9
Characteristic Shear	C20/25	V _{RR}	kN	9.0	14.0	21.0	39.0	61.0	88.0	140.0
Design Resistance	C20/25	N _{Rd}	kN	11.1	16.7	22.2	27.8	41.7	50.0	77.7
Design Shear	C20/25	V _{Rd}	kN	7.2	11.2	16.8	31.2	48.8	70.4	112.0
Design Bending Moment		M	Nm	11.9	23.8	42.1	106.7	207.9	359.4	402.0
Recommended Tension Loads	C20/25	N _{rec}	kN	7.9	11.9	15.9	19.9	29.7	35.7	55.5
Recommended Shear Loads	5.8 steel	V _{rec}	kN	5.1	8.0	12.0	22.3	34.9	50.3	80.0
Part Number				08063	08065	08067	08069	08070	08072	08074
Effective Anchorage Depth		h _{ef}	mm	80	90	110	125	170	210	280
Spacing		S _{cr,N}	mm	140	180	220	250	340	420	700
Edge Distance		C _{cr,N}	mm	120	90	110	125	170	210	350
Minimum Spacing		S _{min}	mm	40	45	55	65	85	105	280
Minimum Edge Distance		C _{min}	mm	40	45	55	65	85	105	140
Minimum Thickness of Concrete		h _{min}	mm	110	120	140	160	220	260	330
Installation Parameters										
Drill Hole Diameter		d _o	mm	10	12	14	18	25	28	35
Clearance Hole in Fixture		d _r	mm	9	12	14	18	22	26	33
Depth of Drill Hole		h _o	mm	80	90	110	125	170	210	280
Installation Torque		T _{inst}	Nm	10	20	40	80	120	180	400
Width Across Nut		SW	mm	13	17	19	24	30	36	46
Width Across Nut (Threaded Stud)		SW	mm	5	6	8	12	14	17	-

NOTE: Load data is taken from Permissible Service Conditions of ETA 09/0192. Approved loads for single anchor without influence of spacing and edge distance for temperature -40°C to +80°C Total safety factor as per ETAG 001 included.

IMPORTANT NOTE: Performance based on clean holes; HAMMER DRILLED - blown and then brushed with a stiff metal brush & blown again.

Stud Setting Tool



size	reference
M8	07370
M10	07371
M12	07372
M16	07373
M20	07374
M24	07375
M30	07376
for use with stud without external hexagon	

STORAGE / SHELF LIFE	IMPORTANT
This product should be stored between +5°C & +25°C.	The information and data given is based on our own experience, research and testing and is believed to be reliable and accurate. However, as Chemfix Products cannot know the varied use to which its products may be applied, or the methods of application used, no warranty as to the fitness or suitability of its products is given or implied. It is the user's responsibility to determine suitability of use. For further information please contact our Technical Department.
The Shelf life of the product is 24 months from the manufacture date.	

SUPERCAP

Glass Capsules

Installation Instructions

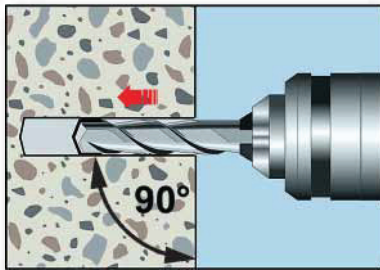

- 1 Drill the anchor hole with a rotary hammer according to the dimensions in the Installation Dimensions Table.

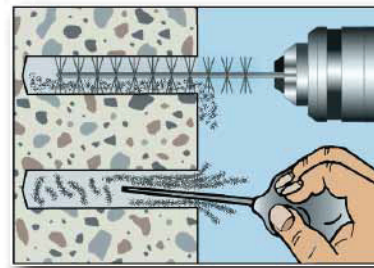

- 2 Clean anchor hole thoroughly by min. 2x blowing out min 2 x brushing and min. 2x blowing out. Remove any remaining water from drill hole.

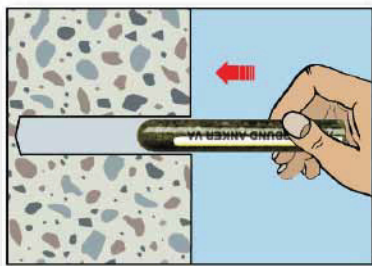

- 3 Insert the capsule to the bottom of the cleaned hole.

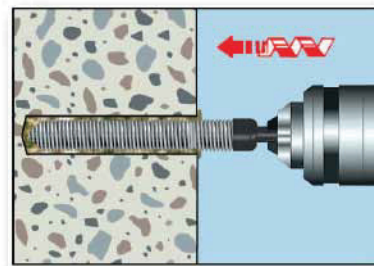

- 4 Install a clean anchor rod (free of any oil, grease or oxidation) with a rotary hammer (250-500 rpm). Stop rotating immediately upon reaching the bottom of the anchor hole.

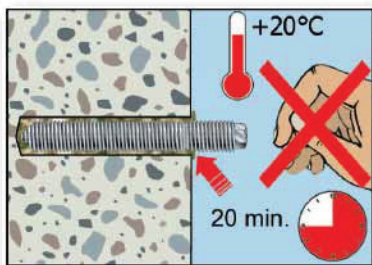

- 5 The installation is correct when the marking on the anchor rod is level with the concrete surface and the void around the anchor rod is filled completely.

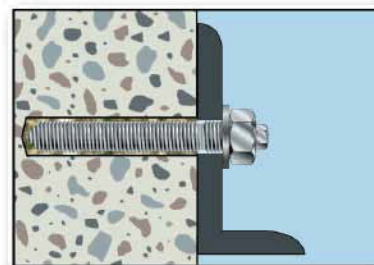

- 6 Observe curing times before loading the anchor. Do not disturb or load the anchor rod until the specified curing time has elapsed.

SUPERCAP

Glass Capsules

Working and Hardening Time

Base Material Temperature	5°C	15°C	25°C	30°C
Gel Working Time	300'	60'	20'	10'
Curing Time Dry Concrete	300'	60'	20'	10'
Curing Time Wet Concrete	x 2	x 2	x 2	x 2

Drill Hole Cleaning Accessories



Blow Out Pump	reference	drill hole Ø	body length	box qty	weight ea.
190mm	07001	12-35mm	190mm	24	0.15kg
280mm	07002	12-35mm	280mm	24	0.225kg
400mm	07003	12-35mm	400mm	24	0.5kg



Steel Brush	reference	drill hole Ø	hole depth	box qty	weight ea.
10mmØ handle 200mm head 80mm	07018	8-10mm	250mm	100	0.02kg
13mmØ handle 200mm head 80mm	07015	12-16mm	250mm	100	0.02kg
18mmØ handle 200mm head 80mm	07016	18-24mm	250mm	72	0.025kg
28mmØ handle 200mm head 80mm	07017	28-35mm	250mm	36	0.025kg

SUPERCAP

Glass Capsules



M8 - M30
sizes
available

Spin-In or
Hammer-In
Type available

Bespoke Capsule
Printing

Manufactured
to ISO 9002

