

# MAPEBAND TPE

TPE tape for flexible sealing and waterproofing expansion joints and over cracks subject to movement



## WHERE TO USE

Waterproofing expansion joints in road-works, tunnels, hydraulic works and covering areas subject to movement up to 5 or 10 mm, using **Mapeband TPE 170** or **Mapeband TPE 325** respectively.

### Some typical application examples

- Flexible waterproofing seal of expansion joints subject to large amounts of movement in service.
- Flexible waterproofing seals in tunnels, road-works, etc.
- Sealing expansion joints in prefabricated panels.
- Sealing structural joints in façades.
- Sealing joints in hydraulic works, such as channels, basins, drains, pipe-work, etc.
- Waterproofing joints in road-works.
- Waterproofing expansion joints in flat covering layers (under tiles or using suitable protection such as a metallic profile).

## TECHNICAL CHARACTERISTICS

**Mapeband TPE** consists of either 17 cm or 32.5 cm wide tape, called respectively **Mapeband TPE 170** and **Mapeband TPE 325**, 1.2 mm thick, sidelong reinforced with polyester non-woven fabric.

**Mapeband TPE** must be applied by bonding with **Adesilex PG4** two-component, low viscosity, thixotropic epoxy adhesive. TPE, short for “Elastomeric Thermoplastic Polyolefine”, is the name given to a special group of polyolefines which combine the best properties of thermoplastic polymers and synthetic elastomer technology.

**Mapeband TPE** may be hot-welded with a Leister electronic hot air blower.

**Mapeband TPE** may be also joined by using the “cold-weld” technique by applying a contact adhesive, such as **Adesilex LP** solvented, poly-chloroprene adhesive, to both surfaces. This technique makes it easy to form linear joints or to create special pieces with the tape, to guarantee the waterproof integrity of the entire system.

The tape remains permanently flexible and deformable even at low temperatures and, furthermore, it is resistant to ageing even if exposed to atmospheric agents.

The composition of **Mapeband TPE** gives it excellent resistance to alkalis, bitumen, diluted lye, slightly acidic solutions and salt solutions.

## RECOMMENDATIONS

- Do not use **Mapeband TPE** if it will come into contact with mineral oil, petrol or strong solvents (ketones, esters and hydrocarbons).
- Do not lay **Mapeband TPE** on surfaces which are not perfectly clean, dry or which are irregular.
- Protect **Mapeband TPE** against perforation.
- In case of permanent contact with liquids at high temperature it is advisable to previously evaluate the application of the product and consult MAPEI Technical Service Department.

# APPLICATION PROCEDURE

## Preparation of the substrate

Surfaces on which **Mapeband TPE** is to be applied must be free from oil, grease and paint and must be free from dust and areas which are either uneven or loose.

Paintwork or coatings must be removed by sandblasting or with a sanding disc. This operation is essential if the surfaces have been treated with polyester, epoxy or polyurethane resin or if it is made from glassy material.

If **Mapeband TPE** is to be applied on metallic surfaces, remove all traces of rust, paint, grease, etc. by sandblasting down to bare metal.

When **Mapeband TPE** is applied, the surface must be perfectly dry.

To obtain a joint with a clean, well-defined profile, apply masking tape around the outside surface of the joint, in order to obtain an area which is 1 cm wider than the width of the TPE tape to be spread with adhesive (fig. 1). After laying, bonding and finishing off with a trowel, remove the masking tape.

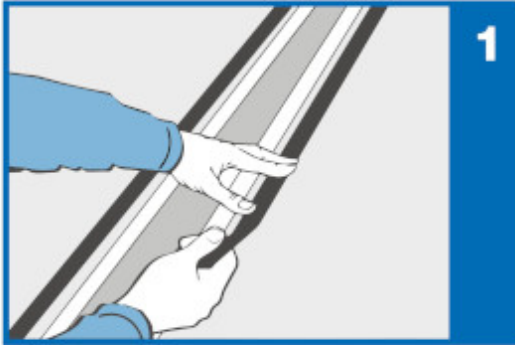

## Products to use for bonding

**Adesilex PG4**, two component, low viscosity, thixotropic epoxy adhesive.

## Preparation of Adesilex PG4 adhesive

The two components which make up **Adesilex PG4** must be mixed together.

Pour component B (white-coloured catalyst) into component A (grey) and mix together with a low-speed drill fitted with a mixing attachment until a homogenous mix is obtained (uniform grey colour).

The packages are pre-dosed. Therefore, do not use only partial quantities of the two components in order to avoid errors when calculating the mixing ratio; this could lead to poor or incomplete hardening of the product. If only partial quantities of the components are used, use high-precision electronic scales.

## Bonding the product

Firstly apply a 1-2 mm-thick uniform layer of **Adesilex PG4** onto the clean, dry substrate with a smooth spatula; avoid applying the adhesive inside the joint (fig. 2).

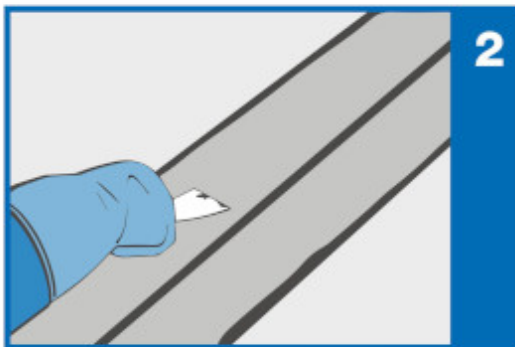

Lay **Mapeband TPE** by pressing lightly along the non-woven sides of the tape. Make sure that all wrinkles and creases are eliminated and that air bubbles are not formed (fig. 3).

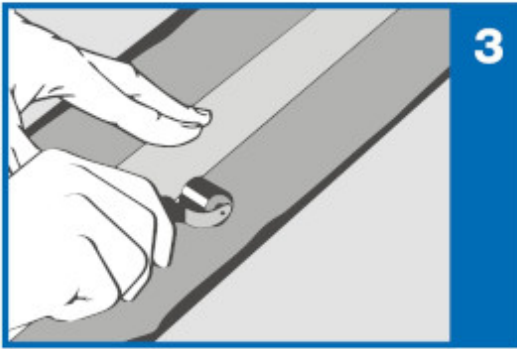

Apply a second layer of **Adesilex PG4** while the first one is still fresh, completely covering the fabric strip with the new layer of adhesive (fig. 4). Smooth off the product with a flat trowel.

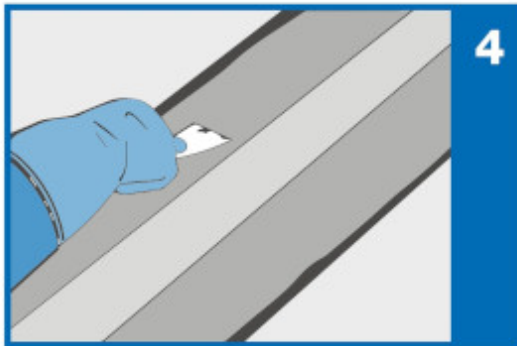

Once the second layer of **Adesilex PG4** has been applied, sprinkle on a layer of **0.5 Quartz** to create a rough surface and slowly remove the masking tape (fig. 5).



**Mapeband TPE** must be protected against damage (e.g. perforation) during the application process. If high levels of movement are foreseen, **Mapeband TPE** must be laid by forming an upside-down “W” (omega) shape on the inside of the joint (fig. 6).

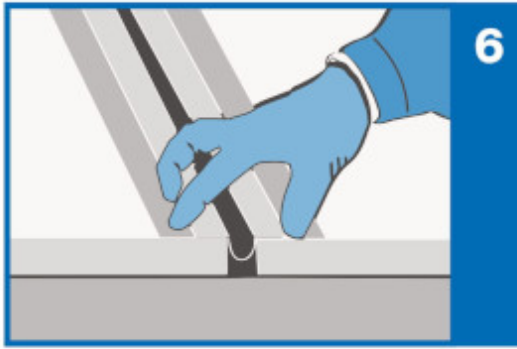

Butt joints between two strips of **Mapeband TPE** must be carried out by overlapping and bonding at least 5 cm of the central part in TPE by either hot-welding or cold-welding, as illustrated previously. To make the welding of the parts in TPE easier and firmer, press lightly with a flat carpeting roller (fig. 9).

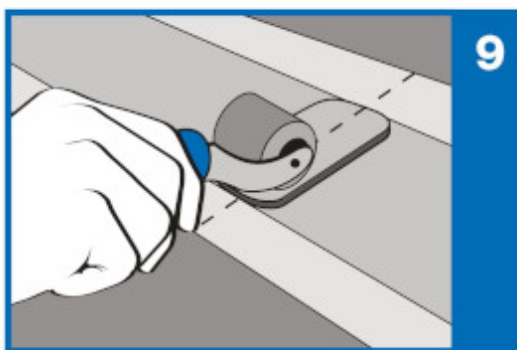
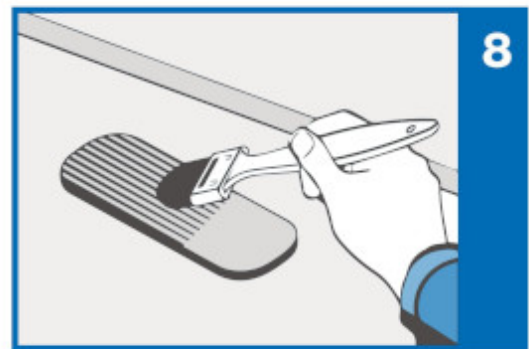
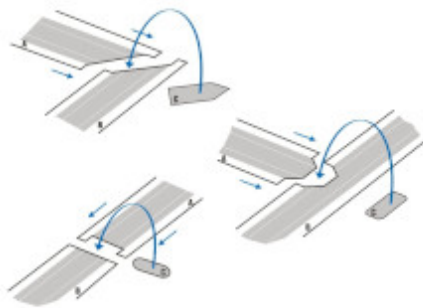

## PACKAGING

Mapeband TPE is supplied in boxes and is available in two sizes:

- Mapeband TPE 170 (width 17 cm): 30 m x 17 cm rolls;
- Mapeband TPE 325 (width 32.5 cm): 30 m x 32.5 cm rolls.

## SAFETY INSTRUCTIONS FOR PREPARATION AND APPLICATION

**Mapeband TPE** is an article and referring to the current European regulations (Reg. 1906/2007/CE - REACH) does not require the preparation of the material Safety Data Sheet. During use it is recommended to wear protective gloves and goggles and follow the safety requirements of the workplace.  
**PRODUCT FOR PROFESSIONAL USE.**

<b>TECHNICAL DATA (typical values)</b>	
<b>PRODUCT IDENTITY</b>	
<b>Colour:</b>	grey
<b>Sizes available:</b>	17 cm ( <b>Mapeband TPE 170</b> ) 32.5 cm ( <b>Mapeband TPE 325</b> )
<b>Width of expansion area (mm):</b> – Mapeband TPE 170: – Mapeband TPE 325:	50 165
<b>Thickness (EN 1849-2) (mm):</b>	1.2
<b>FINAL PERFORMANCES</b>	
<b>Breaking load (EN 12311-2) (N/mm<sup>2</sup>):</b>	> 4.5
<b>Elongation at break (EN 12311-2) (%):</b>	> 500
<b>Low-temperature bending (EN 495-5) (°C):</b>	< -30
<b>Resistance to atmospheric agents and ultraviolet rays (EN 1297):</b>	pass (> 5000 h / degree 0)
<b>Resistance to roots (SIA V280/11):</b>	no root penetration
<b>Reaction to fire (EN 13501-1) (Euroclass):</b>	E
<b>Waterproofing level (EN 1928-B) (bar):</b>	6
<b>Permeability to water vapour (EN 1931):</b>	$\mu$ = approx. 30000
<b>Perforation resistance (SIA C280/15) (500 g from dropped height) (mm):</b>	> 500
<b>Resistance to temperature:</b>	from -20°C to +50°C
<b>Maximum elongation of expansion zone (mm):</b> – Mapeband TPE 170: – Mapeband TPE 325:	5 10

## WARNING

---

*Although the technical details and recommendations contained in this product data sheet correspond to the best of our knowledge and experience, all the above information must, in every case, be taken as merely indicative and subject to confirmation after long-term practical application; for this reason, anyone who intends to use the product must ensure beforehand that it is suitable for the envisaged application. In every case, the user alone is fully responsible for any consequences deriving from the use of the product.*

**Please refer to the current version of the Technical Data Sheet, available from our website [www.mapei.com](http://www.mapei.com)**

## LEGAL NOTICE

---

*The contents of this Technical Data Sheet ("TDS") may be copied into another project-related document, but the resulting document shall not supplement or replace requirements per the TDS in force at the time of the MAPEI product installation.*

*The most up-to-date TDS can be downloaded from our website [www.mapei.com](http://www.mapei.com).*

**ANY ALTERATION TO THE WORDING OR REQUIREMENTS CONTAINED OR DERIVED FROM THIS TDS EXCLUDES THE RESPONSIBILITY OF MAPEI.**

2033-3-2022 en (IT)

Any reproduction of texts, photos and illustrations published here is prohibited and subject to prosecution

